

Panelplayer



Shopping malls

Shops

Museums

Fairs

PanelPlayer is a highly evolved audio device with a solid state memory, designed to manage quickly, effectively and interactively, sequences of audio messages, musical pieces, commercial notices and MP3 audio files.



Via Nobel, 10 - 30020 Noventa di Piave (VE) - Italy
Tel +39 0421 571411 - Fax +39 0421 571480
info@inout-digital.com - www.inout-digital.com



Plus

- High audio quality (comparable to CD).
- Very high memory capacity: PanelPlayer can manage more than 16 hours of MP3 audio files, depending on the size of the memory used.
- Reliability of the audio tracks: digital memorization guarantees the preservation through time of the quality features of the recorded audio files.
- Hardware reliability: PanelPlayer has no moving mechanical parts, so it is not subject to any kind of wear.
- Extractable memory, for quick updating of the audio files.
- Easy, quick and intuitive audio files management.
- Instant playing of the musical piece, whatever the point of memorization of the audio track may be.
- Essential system: PanelPlayer requires no specific software for storing and managing the audio files.
- The audio files may be transferred very quickly to and from PC using a USB reader/writer (indicative transfer time for audio files lasting 1 hour, about 1 minute).
- Sturdiness and compact design on flat metal container.
- Compact Flash configuration software included.

Programmable functions:

- **PLAYLIST:** operation with several playlists or sequences of audio files which can be activated via logical inputs.
- **SLAVE:** 8 digital inputs for the playing of maximum 255 messages/audio in binary combination.
- **SERIAL RS485:** to interface with control systems for direct recalling of any messages/audio files stored in SD/MMC memory; no limitations on the number of files.
- **TIMED:** sequence of audio notices issued cyclically, consisting of single messages or blocks of at most 8 files, with a maximum programming of 1 hour. Synchronization with connection of more PanelPlayer.
- PanelPlayer has an audio input for connection to outside music sources: at the programmed event, the input audio signal fades out in a programmed manner.



PanelPlayer is an evolved MP3 audio player, which allows you to create interactive areas, teaching and museum routes, information totems for exhibitions, musical scenery, interactive points for commercial promos, relax areas, etc.

PanelPlayer is interactive, since it directly captures the attention of the people moving nearby with commercial slogans or with a series of notices activated by a small infrared sensor, which can be camouflaged in the best position from an aesthetic point of view.

The system can be combined with panels printed with customised graphics, with a high emotional impact: the panel itself acts as an acoustic amplifier with a wide sound distribution using specific Exciters: a perfect match in order to advertise using intelligence and creativity.

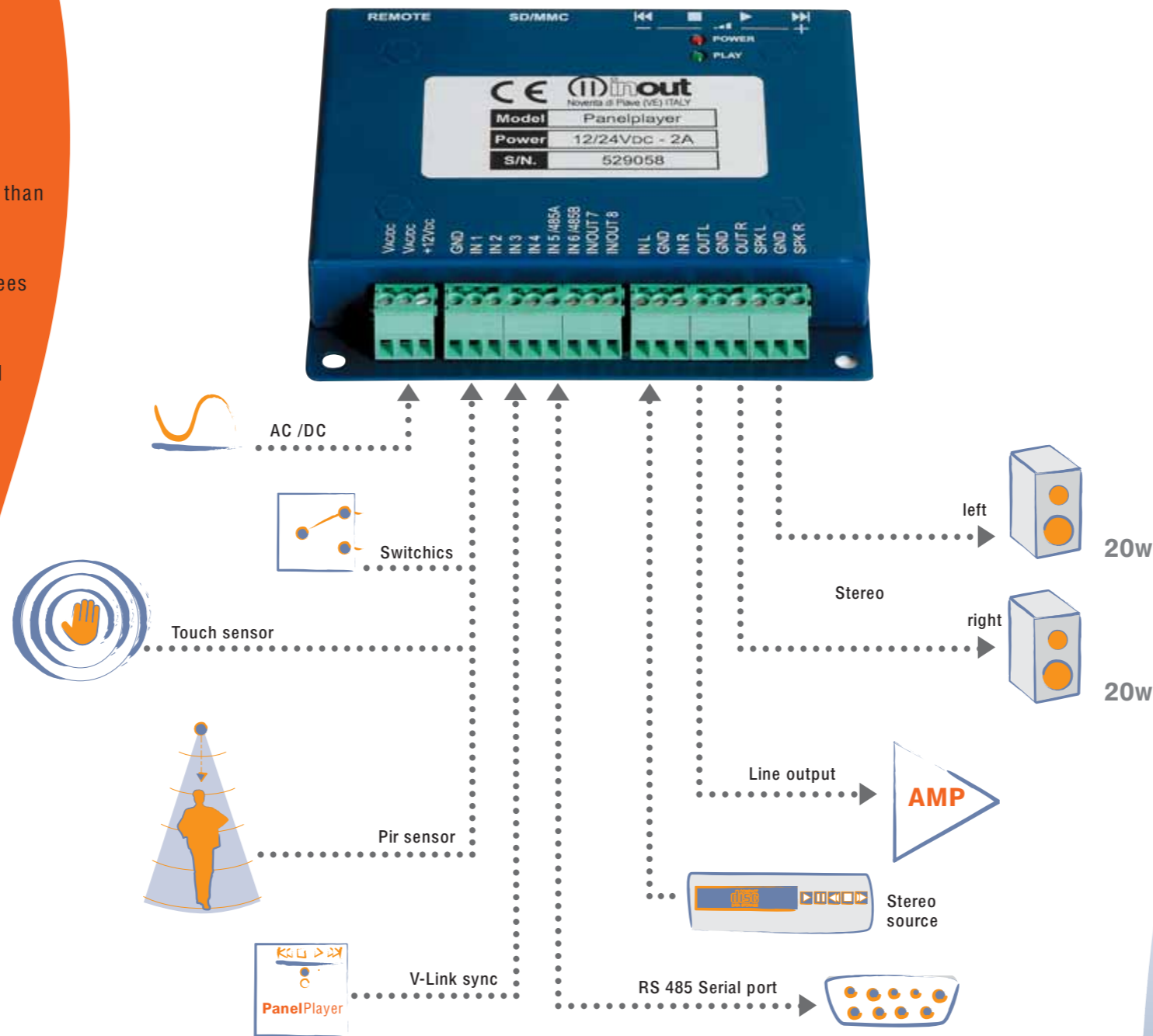

PanelPlayer is an evolved MP3 audio player, which allows you to create interactive areas, teaching and museum routes, information totems for exhibitions, musical scenery, interactive points for commercial promos, relax areas, etc.

PanelPlayer is a high technology device. In a very small space you can have:

- Player of MP3 audio files memorised on extractable Secure Digital or MultiMedia Card memory;
- Amplifier in class D stereo 20+20W, configurable mono (bridge) 40W;
- 8 inputs for single playing, in sequence or in binary combination of audio messages, preset for the connection of buttons, touch sensor, infrared movement sensors;
- 1 RS485 serial port for connection to outside control systems;
- Audio Mixer to mix an outside audio source;
- Audio limiter for automatic control of the output volume.

Technical Characteristics

- Mains voltage ~12÷15VAC o 12÷24VDC
- 6/8 multi-purpose inputs for single, sequence playlist or binary combination playing. Activation with state 0 or state 1 programmable.
- Inputs/outputs available on removable strip barrier.
- VLink programmable output.
- Preamplified L+R stereo audio input for external music source, mixable with MP3 audio.
- Preamplified L+R stereo audio output (0dB).
- Amplified stereo audio output 20W+20W or 40W (bridge, 4 ohm). Amplifier in class D with top efficiency, no heat generation.
- 1 serial RS 485 communication port for interfacing with external control systems.
- 1 REMOTE connector for outside connection of the SD/MMC memory and of the command buttons.
- 4 buttons: play, stop, track forward, track back and output volume.
- 1 red LED: power on.
- 1 green LED: play/standby.

Setting and storing configuration parameters in the memory:

- MP3 level, source input level, general output level
- level of background music during the broadcasting of the spots
- separate high and low tone levels
- Loudness level
- reaction time of the automatic output volume control
- persistence time of the command on the logical inputs
- loop/continuous play mode
- restart mode
- automatic programmable fade of the external source during the playing of the files.
- Setting the AUTOPLAY time for playing a message when it is not activated by the sensor.
- Delay time between two activations of the IR sensor.
- Delay time of file playing after activation of the IR sensor.
- Size 102x102x18 mm.
- Preset for mounting on DIN bar with proper accessory.
- Memories: Secure Digital and MultiMedia Card with capacity from 32MB to 1GB.
- MP3 formats: MPEG1 layer 3 (file MP3 from 64 to 160 Kbps).
- Frequency response: 20 ~ 20.000 Hz (±3dB).
- Signal/noise ratio:> 90dB.
- Harmonic distortion:<0,1%.
- Flash memory included.
- Compact Flash configuration software included.

